

Design of Low Cost Modem Using Tele Typewriter Signals

D. Muthu Kumaran¹, C. Charithartha Reddy², C. Annadurai³

^{1,2}Final Year Students, ³Assistant Professor, Department of ECE,
SSN College of Engineering, Kalavakkam, Tamil Nadu
muthukumaran.parktown@gmail.com

Abstract -A Low cost Wireless Data Modem using Tele Typewriter Signals and Frequency Shift Keying (FSK) Modulation Technique is proposed here. Basically a Modem sends and receives Digital data signals to and from various Computer Networks and peripheral devices. The transmission media used in most of the Modem is Fiber Optic cable. The main reason for using Fiber Optic cable is to avoid Electro Magnetic Interference (EMI). But the cost involved in using this Fiber Optic cable is high. So our aim is to design a modem whose transmission medium can be laid with low cost as well as the modem should avoid Electro Magnetic Interference (EMI). The Wireless Modem designed here consists of 5 stages namely a) Modulation stage, b) Transmission stage, c) Reception stage, d) Filtering stage and e) Demodulation stage. The Modulation stage consists of IC 555 Timer working in Astable Mode and generating Frequency Shift Keying (FSK) signals. Transmission is Wireless and is achieved using IR LED. The Transmitted signal is received using a spectrally matched Phototransistor. The Filtering stage consists of a second order Low Pass Filter (LPF). Demodulation is achieved using IC565 (Phase Locked Loop) which recovers the input message signal. The modem designed here makes use of Tele Typewriter signals which neglects conduction and radiation interference from external environment. The Bandwidth of such Tele Typewriter signals is 200Hz. For signals with such lower bandwidth Frequency Shift Keying (FSK) is the best Modulation Technique for transmitting digital information. The Probability of Error for this Wireless Data Modem is better with minimal Bit Error Rate (BER). The wireless transmission medium is achieved using the combination of IR LED and Phototransistor. So the cost involved in this transmission medium is very low compared to Fiber Optic cable. Hence the whole setup is Stable, cheap and accurate device for transmitting digital data.

Index terms -Frequency Shift Keying (FSK), Tele Typewriter signals, Low Pass Filter (LPF), Electro Magnetic Interference (EMI), Phase Locked Loop (PLL), Probability of Error, Bit Error Rate (BER), Fiber Optic cable, cost.

1. INTRODUCTION

Wireless Data Modem plays a very vital role in the field of digital data communication. In this scientific era, data transfer is very crucial and most of the data transfer between various computer networks and peripheral devices is done using Modem. The transmission medium used in Modem is Fiber Optic cable which is cable of avoiding Electro

Magnetic Interference (EMI). But the cost involved in using Fiber Optic cable as the transmission medium is very high. So the alternate choice is to use a wireless Medium which is cheap. But wireless medium is not immune to Electro Magnetic Interference (EMI). So for improving the immunity of the Modem against Electro Magnetic Interference (EMI) we use Tele Type Writer signals. For the transfer of digital data using Tele Type writer signals whose frequency range is from 1070Hz to 1270Hz, a Wireless Data modem is proposed. The Tele Typewriter includes a Start Signal, Data information defined by signal transitions between 1070Hz to 1270Hz and a stop signal which are operated upon so that they are converted to signals adopted for use in digital logic circuits in a unique manner to neglect Electro Magnetic Interference (EMI) of both the radiation and conduction type. So for transmitting digital information using such signals, the basic modulation and demodulation technique used is Frequency Shift Keying (FSK). It is one of the Frequency Modulation technique in which Digital data to be transmitted by means of a carrier signal whose frequency is shifted between two preset frequencies namely f_H and f_L , where f_H corresponds to logic 1 and f_L corresponds to logic 0 of the input binary message data to be transmitted. The process of FSK modulation can be best understood by means of Figure 1. The message signal to be transmitted is in the binary form of 0's and 1's. The carrier signal is a continuous analog signal of desired frequency as shown in Figure 1. So when the message signal is of logic 1, the resultant modulated signal's frequency will be f_H . When the message signal is of logic 0, the resultant modulated signal's frequency will be f_L . Thus the carrier signal frequency is shifted between two preset frequencies. Thus the resultant FSK modulated signal is shown in the Figure 1.

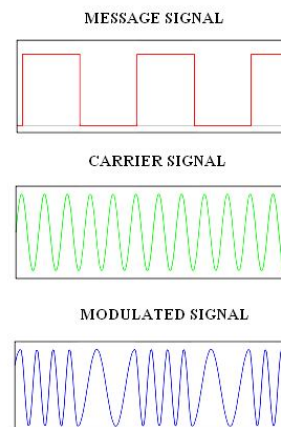

Figure 1: Frequency Shift Keying Modulation

So for transmitting digital data using Tele Typewriter Signals, we use $f_H=1070\text{Hz}$ and $f_L=1270\text{Hz}$. The major reason for choosing Frequency Shift Keying modulation technique is due to the small bandwidth requirement of the Tele Typewriter signals. The Bandwidth is 200Hz which is very low. The usage other modulation techniques like amplitude modulation or other frequency modulation techniques like ASK (Amplitude Shift Keying), PSK (Phase Shift Keying), the input binary message signal is not effectively reproduced. The obtained message signal is distorted and does not resemble the input message signal. The accuracy of FSK technique is better than other modulation techniques. The Probability of Error of FSK technique is also good. So because of these reasons Frequency Shift keying has been selected as the modulation technique in our modem.

2. BLOCK DIAGRAM DESCRIPTION

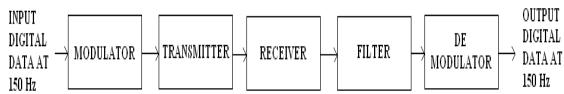

Figure 2: Block Diagram

The basic block diagram of the Wireless Data Modem is shown in Figure 2. It consists of five stages namely a) Modulator Stage, b) Transmitter Stage, c) Receiver Stage, d) Filter stage and e) Demodulator Stage. The aim is to transmit the Input digital data effectively from one network to another network or from one network to other peripheral devices. The first step is to modulate the input digital data with the carrier signal using Frequency Shift Keying Modulation Technique. This is achieved using IC 555 Timer, which produces the FSK modulated signal whose $f_H=1070\text{Hz}$ and $f_L=1270\text{Hz}$, which means that when the input message signal is of logic 1 the frequency of the modulated signal is 1070Hz and when the input message signal is of logic 0 the frequency of the modulated signal is 1270Hz . The modulated signal is then transmitted using IR LED. Thus Wireless Data transfer is achieved by the using IR LED.

The transmitted signal is received at the Receiver side by means of a spectrally matched Phototransistor which then sends the obtained modulated signal to the Filter Stage. The Filter stage consists of a Second order Low Pass Filter (LPF). The final stage is the Demodulator stage which consists of Phase Locked Loop (PLL) and a RC ladder Filter. The Phase Locked Loop is implemented using IC 565. Thus the demodulator Stage separates the message signal from the carrier signal and hence the digital data signal is obtained successfully. The Baud rate which denotes the rate of transfer of data for this modem is given as

$$\text{Baud rate} = \frac{1}{\Delta} \tag{1}$$

Here $\Delta = (\Delta_1 + \Delta_2) = 1.722\text{ms}$, $\Delta_1 = 0.935\text{ms}$, $\Delta_2 = 0.787\text{ms}$, where Δ_1 is the time during which bit 1 lasts and Δ_2 is the time during which bit 0 lasts and hence the Baud Rate is 580 bps (Bits per Second).

3. MODULATION

Modulation is the process of altering the characteristics of the carrier signal in accordance to the message signal. Here Frequency Shift Keying Modulated signal is obtained using IC 555 Timer. The circuit diagram for FSK Signal generation using IC 555 Timer is shown in Figure 3. It consists of a IC 555 Timer which works in Astable Mode. The resistors R_a , R_b and capacitor C determines the Frequency of the FSK modulated signal. The standard digital data input frequency is usually 150Hz . When the input is HIGH i.e. when the input binary data is of logic 1, the PNP transistor Q is off and IC 555 Timer works in the normal astable mode of operation. The frequency of the output FSK modulated signal is given by the equation

$$f_0 = 1.45 / (R_a + 2R_b)C \tag{2}$$

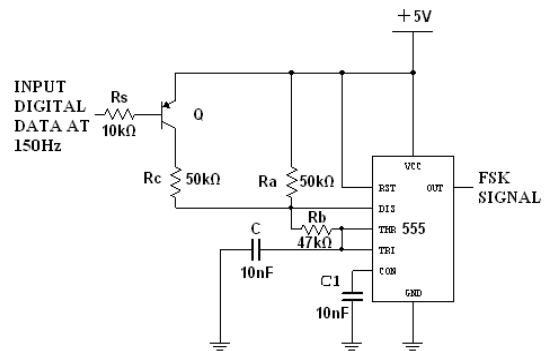

Figure 3: FSK Generation using IC 555 timer

The Resistors R_a , R_b and capacitor C are selected in such a way that the value of f_0 is 1070Hz . The circuit diagram when the input is HIGH is shown in the Figure 4.

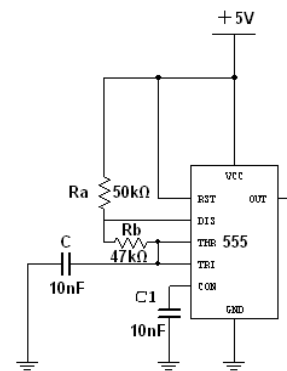

Figure 4: When the Input is HIGH

Here the values of $R_a = 50\text{K ohm}$, $R_b = 47\text{K ohm}$ and $C = 10\text{nF}$. When the input is LOW i.e. when the input binary data is of logic 0, the PNP transistor Q is on and its connects the resistance R_c across the resistance R_a . Thus now the frequency of the output FSK modulated signal is given by the equation

$$f_0 = 1.45 / ((R_a || R_c) + 2R_b)C \tag{3}$$

The Resistors R_c is selected in such a way that the value of f_0 is 1270Hz . The circuit diagram when the input is LOW is shown in the Figure 5. Here the value of $R_c = 50\text{K ohm}$. The capacitor C_1 is used to bypass noise and ripples from the supply. The resultant FSK modulated signal along with the digital binary input data at 150Hz is shown in the

Figure 6. From the Figure 6 it is evident that during logic 1 of the binary input data $f_H=1070\text{Hz}$ and during logic 0 of the binary input data $f_L=1270\text{Hz}$. Thus the Frequency Shift Keying (FSK) modulated signal is obtained from the modulator stage.

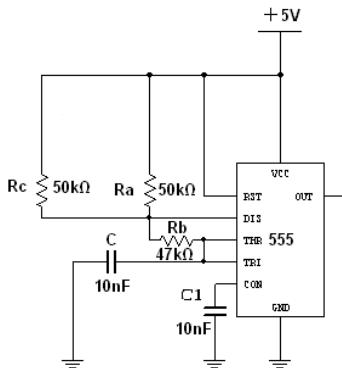

Figure 5: When the Input is LOW

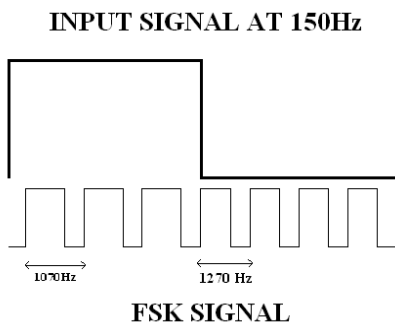

Figure 6: FSK modulated signal

4. TRANSMISSION



Figure 7: IR LED emitter

An infrared emitter is an LED made from Gallium Arsenide, which emits near-infrared energy at about 880nm. The Frequency Shift Keying signal from the Modulator is now wirelessly transmitted to the receiver side using IR LED. The IR LED used as a transmitter is shown in figure 7. The circuit diagram for this process is shown in figure 8. The value of the limiting Resistor R is calculated

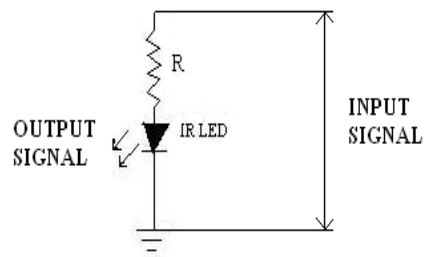

Figure 8: Transmitter using IR LED

using the formula

$$\text{resistance in ohms}(R) = \frac{\text{power supply voltage}(V_s) - \text{LED voltage drop}(V_f)}{\text{LED current rating}(I_f)} \quad (4)$$

Here Supply voltage V_s is 5V, LED Voltage drop V_f is 3.3V and LED current rating I_f is 20mA. Hence the value of R is 85 ohms.

5. RECEPTION



Figure 9: Phototransistor Detector

The infrared Phototransistor acts as a transistor with the base voltage determined by the amount of light hitting the transistor. Hence it acts as a variable current source. Greater amount of IR light cause greater current to flow through the collector-emitter leads. The signal from the Transmitter side should be received at the Receiver side by a spectrally matched Phototransistor. The Phototransistor used as a Receiver is shown in the figure 9. The circuit diagram for this process is shown in figure 10. Thus the whole process of wireless transfer of data is achieved using the combination of IR LED and a spectrally matched Phototransistor. This wireless transmission channel is cheaper in comparison to the transmission medium obtained using Fiber Optic cable. The important parameter for a Modem, which is the Probability of Error is good for this combination of IR LED and phototransistor.

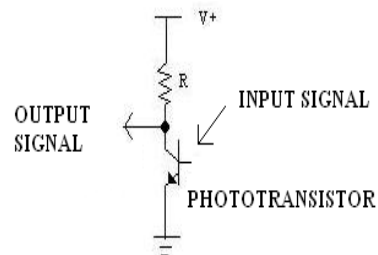

Figure 10: Receiver using Phototransistor

6. FILTER

The Low Pass Filter (LPF) is used to eliminate the unnecessary high frequency components from any low frequency signal and hence helps in improving the Probability of Error of a System. Here a second order LPF as shown in the figure 11 is used to remove the high frequency Noise components introduced by the Wireless Channel. The timing resistors are calculated using the following formulae

$$f_L = 1 / (2 * \pi * R_1 * C_1) \tag{5}$$

$$f_H = 1 / (2 * \pi * R_2 * C_2) \tag{6}$$

So for $f_L = 1070\text{Hz}$ and $f_H = 1270\text{Hz}$, we get $R_1 = 745\text{ ohm}$, $R_2 = 1.25\text{K ohm}$, $C_1 = 200\text{nF}$, $C_2 = 100\text{nF}$.

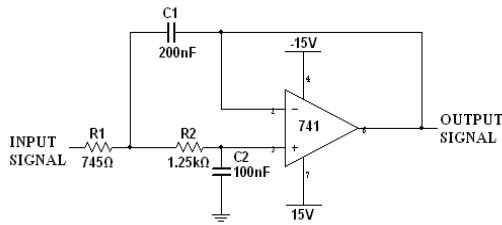

Figure 11: Low Pass Filter

7. DEMODULATION

The process of eliminating the Carrier signal and recovering the base band message signal from the modulated signal is termed as Demodulation. Here the process of demodulation is achieved using Phase Locked Loop (PLL) IC 565. The circuit diagram for achieving the process of demodulation using PLL IC 565 is shown in figure 12. In the 565 PLL the frequency shift is usually accomplished by driving a Voltage Controlled Oscillator (VCO) with the digital data signal so that the two resulting frequencies correspond to the logic 0 and logic 1 states of the digital data signal. The frequencies corresponding to logic 1 and logic 0 states are commonly called the *mark* and *space* frequencies. The demodulator receives a signal at one of the two distinct carrier frequencies 1,270 Hz or 1,070 Hz representing logic levels of mark (- 5 V) or space (+ 14 V), respectively. Capacitance coupling is used at the input to remove a dc level.

As the signal appears at the input of 565 PLL, the PLL locks to the input frequency and tracks it between the two possible frequencies with a corresponding dc shift at the output. Resistor R_1 and capacitor C_1 determine the free-running frequency of the VCO. Capacitor C_2 is a loop filter capacitor that establishes the dynamic characteristics of the demodulator. Capacitor C_2 is chosen smaller than usual one to eliminate overshoot on the output pulse. A three-stage RC ladder filter is employed for removing the sum frequency component from the output.

The VCO frequency is adjusted with R_1 so that the dc voltage level at the output (pin 7) is the same as that at pin 6. An input at frequency 1,070 Hz drives the demodulator output voltage to a more positive voltage level, driving the digital output to the highlevel (space or + 14 V). An input at 1,270 Hz correspondingly drives the 565 dc output less positive with the digital output, which then drops to the low level (mark or - 5 V). The comparator prevents the

amplitude changes occurring at the output stage. Thus the demodulator stage effectively reproduces the input digital data at 150Hz. The resultant digital data signal obtained from the FSK signal by the Demodulation process is shown in figure 13.

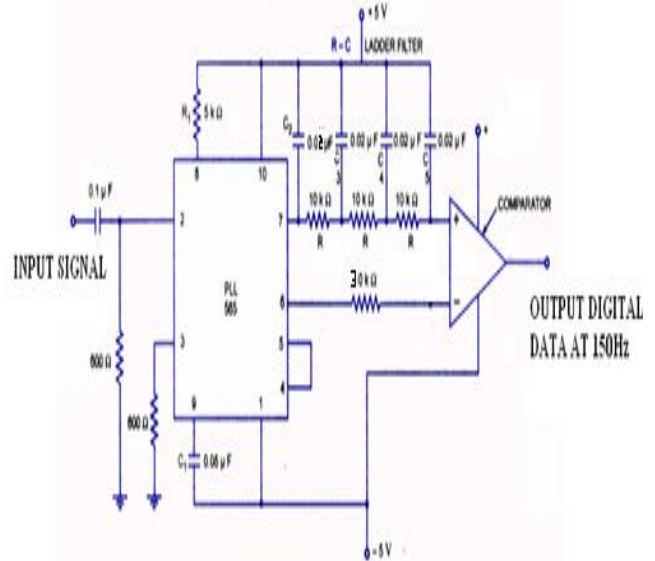

Figure 12: Demodulator using PLL 565

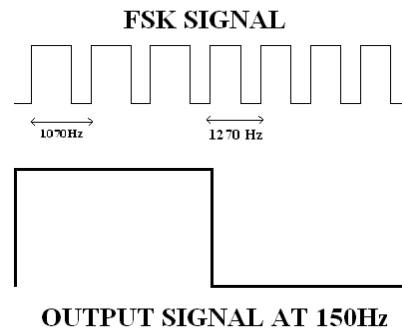

Figure 13: Input Digital data from FSK signal

8. PROBABILITY OF ERROR

The most important parameter that defines the efficiency of a Modem is the Probability of Error and Bit Error Rate (BER). BER means the amount of error introduced in the transmitted signal by the channel's noise. Usually the noise considered in a wireless medium is Additive White Gaussian Noise with zero mean and power Spectral density as $N_0/2$. The expression for Probability of Error for this wireless data modem which uses Non Coherent FSK demodulation is given as

$$p_e = 1/2 * \exp(-E_b / (2 * N_0)) \tag{7}$$

where E_b is the transmitted signals energy per bit. The plot of Probability of Error and E_b/N_0 is shown in Figure 14. From the Figure 14 it is very clear that the Bit Error Rate (BER) for this wireless data Modem is very low.

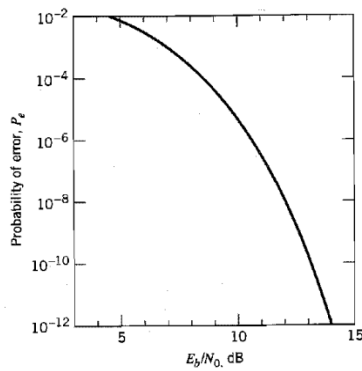

Figure 14: Bit Error Rate (BER)

9. CONCLUSION

Thus in this paper a Low cost Wireless Data Modem using Tele Typewriter signals and Frequency Shift Keying (FSK) Modulation and Demodulation technique is designed and its importance to transmit digital data wirelessly with minimal Bit Error Rate (BER) without getting affected by Electro Magnetic Interference (EMI) of conduction and radiation type from the external environment is analyzed.

REFERENCE

- [1]. Tom McDermott, *Wireless Digital Communications: Design and Theory*, Tucson Amateur Packet Radio Corporation, Tucson, Arizona, 1996.
- [2]. Peyton Z. Peebles, *Digital Communication Systems*, Prentice-Hall, Englewood Cliffs, New Jersey, 1987.
- [3]. Smon Haykins, *Communication Systems*, John Wiley, 4th Edition, 2001.
- [4]. Jhn G. Proakis, *Digital Communication*, McGraw Hill, 3rd Edition, 1995.
- [5]. Tub & Schilling, *Principles of Digital Communication*, Tata McGraw-Hill, 28th reprint, 2003.